



Sweetwater · Gainesville, FL

Unit Furniture Overview

Prepared Spring 2025



Why University Furnishings?

The leader for a reason

✓ 20 years at the forefront

For two decades, we have been the top supplier of furnishings for off-campus student housing projects, offering tailored solutions to meet various project needs.

✓ Unmatched logistics excellence

Our best-in-class logistics and installation processes solidify our position as a trusted partner, effectively mitigating risk for our clients.

✓ Your own client portal

Clients receive a customized online portal for easy access to product history, making reordering or replacing furniture seamless and hassle-free.

✓ 1:1 design process

Unit furniture should enhance the resident experience, bridging the gap between common areas and living spaces. Whether you need budget-friendly options or custom pieces, we'll deliver on time and within budget.

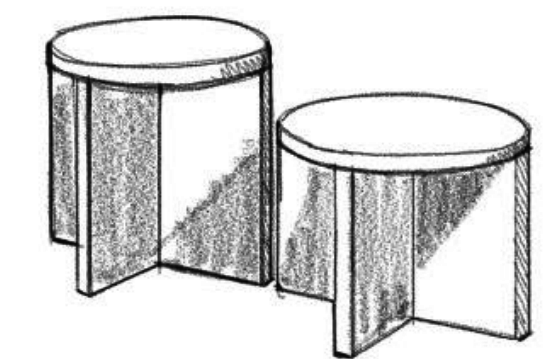
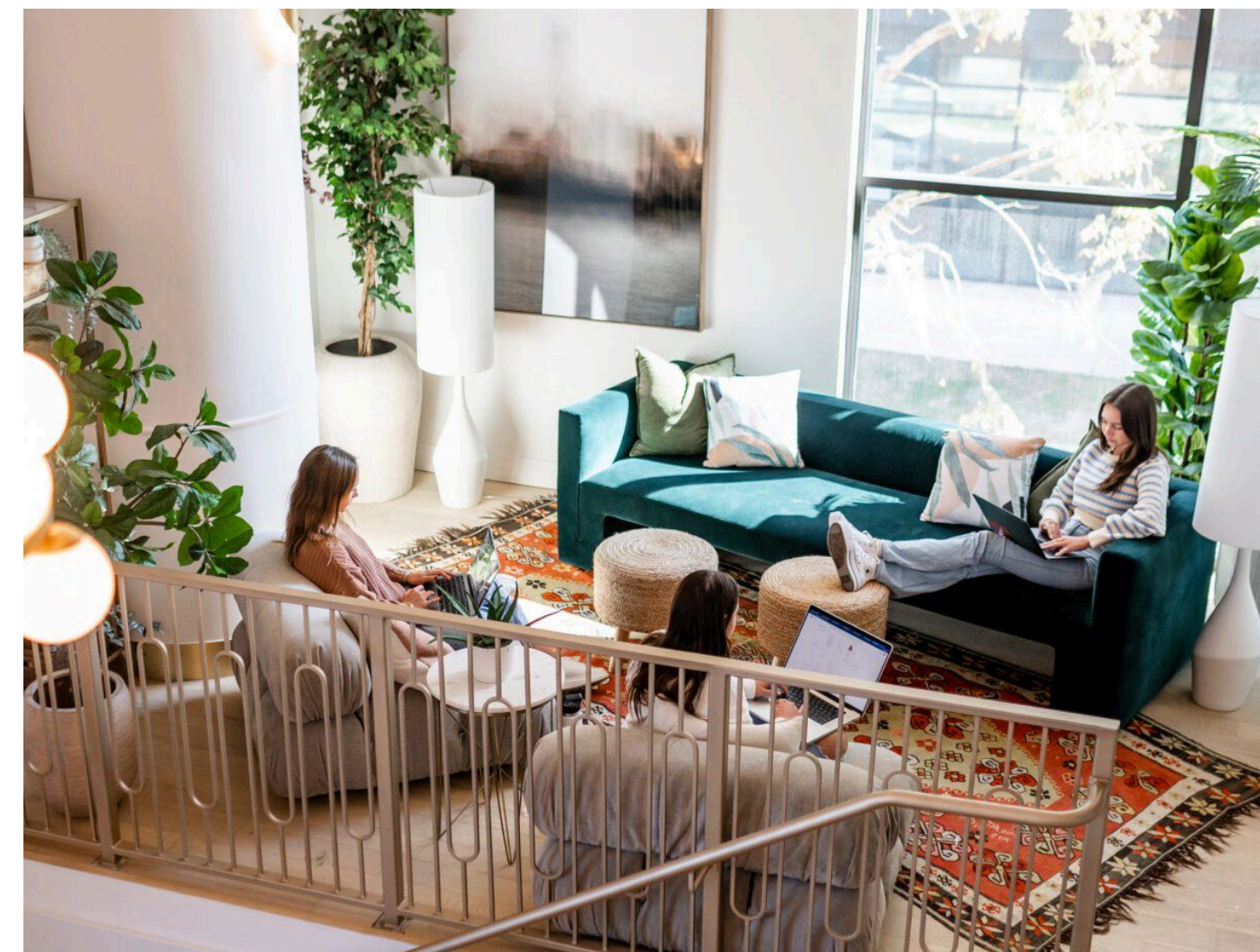
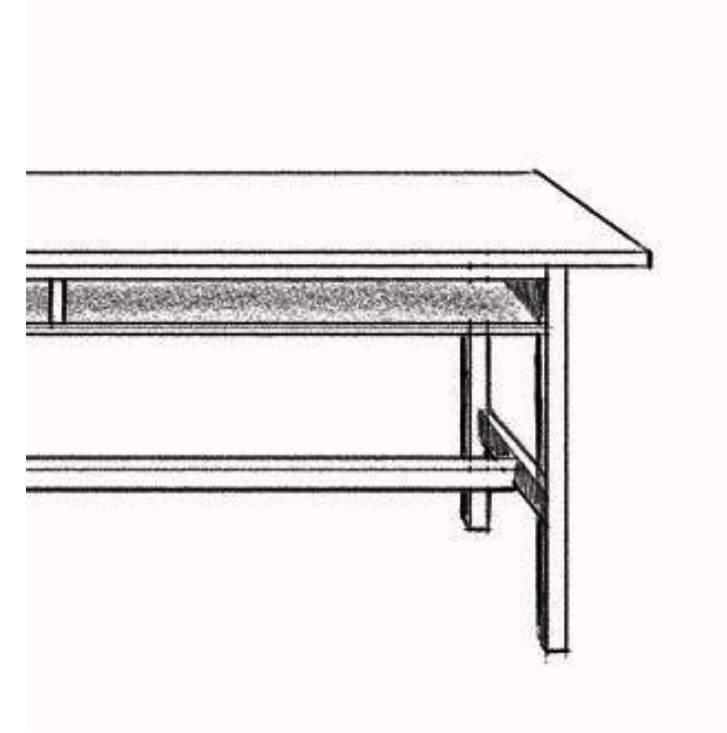

Clockwise from right: UF team reviewing sofa production, table material study, soft good production



Why University Furnishings?

A better approach

Finally: a level of service worth mentioning

Your UF team is only ever a call, email, or text away

We bring your vision to life

Our extensive design and manufacturing expertise is at your disposal

Customizable furniture

We offer beautiful and durable furniture tailored to your properties

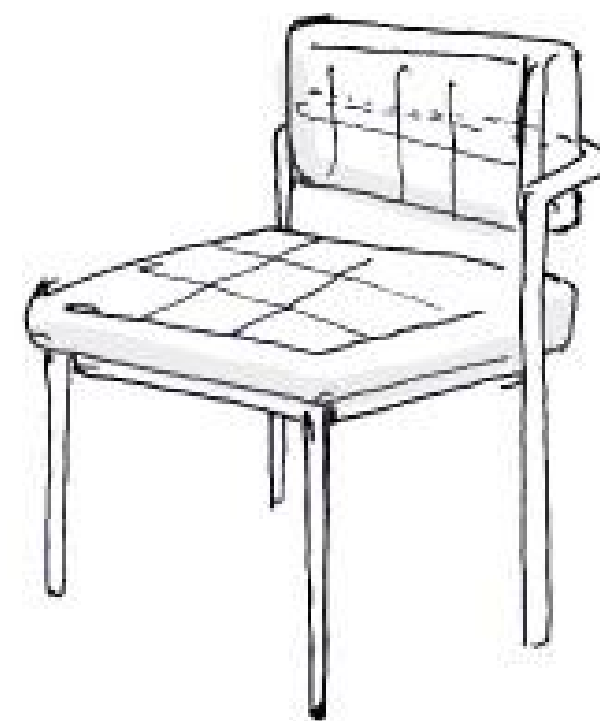
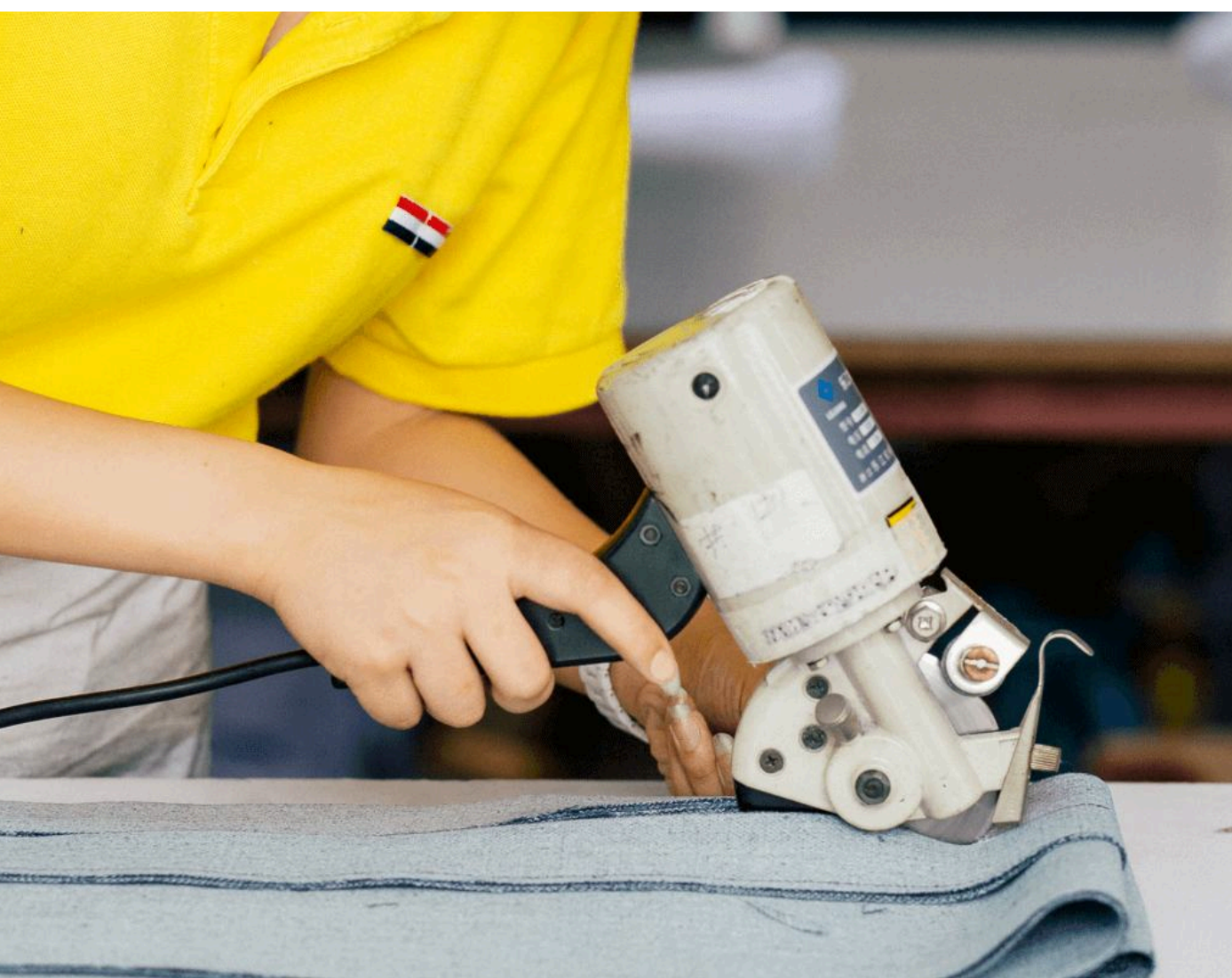

Best-in-class logistics

We're install experts

- ✓ Turn-key customs and duty management
- ✓ Relationships with 45 managed warehouses
- ✓ Furniture delivered to your market 30 days prior to install
- ✓ Dedicated UF staff every day on every job
- ✓ Proprietary logistics software enabling seamless install & invoicing
- ✓ 100% on time delivery record

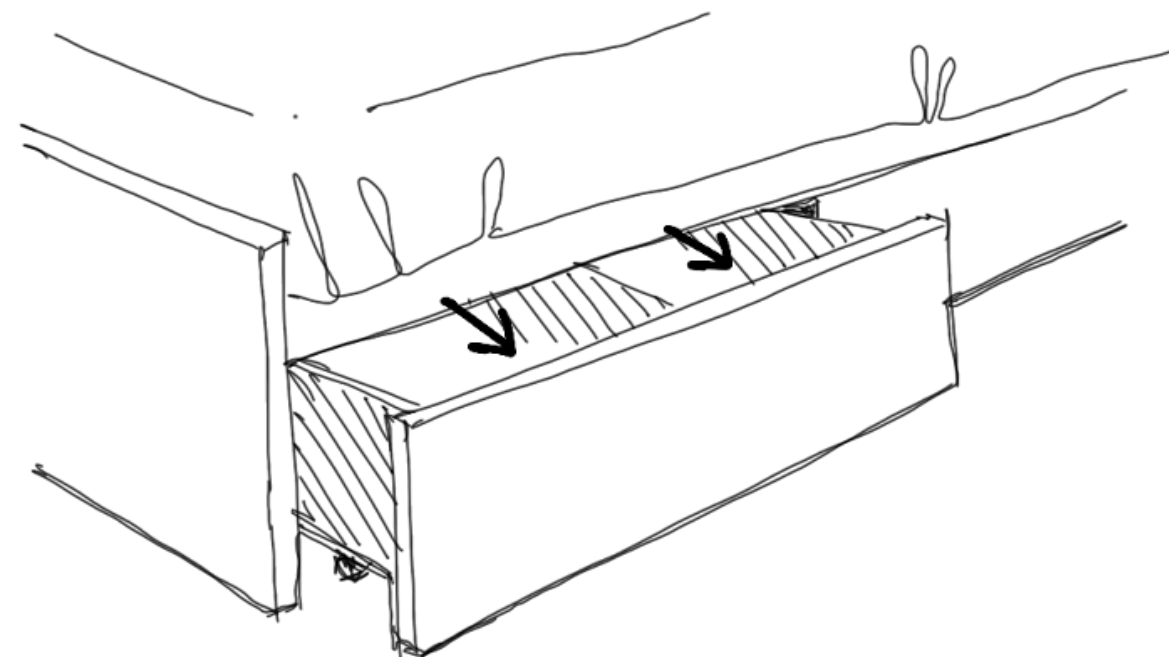
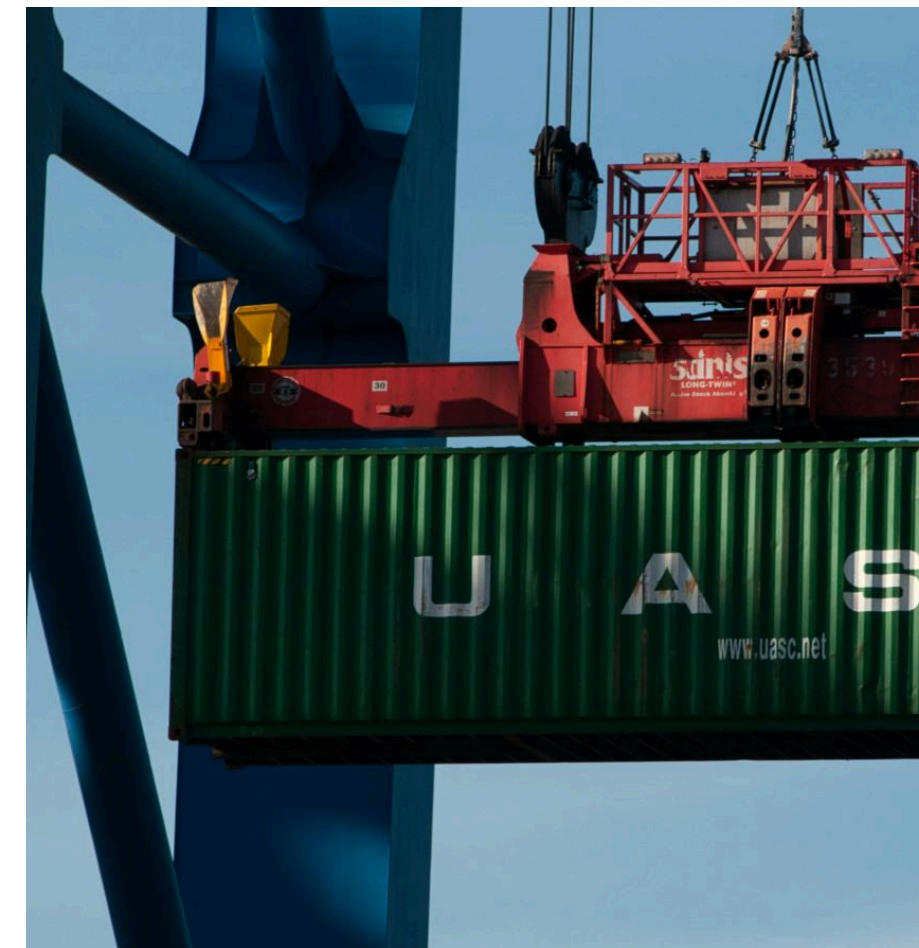

Design driven furniture

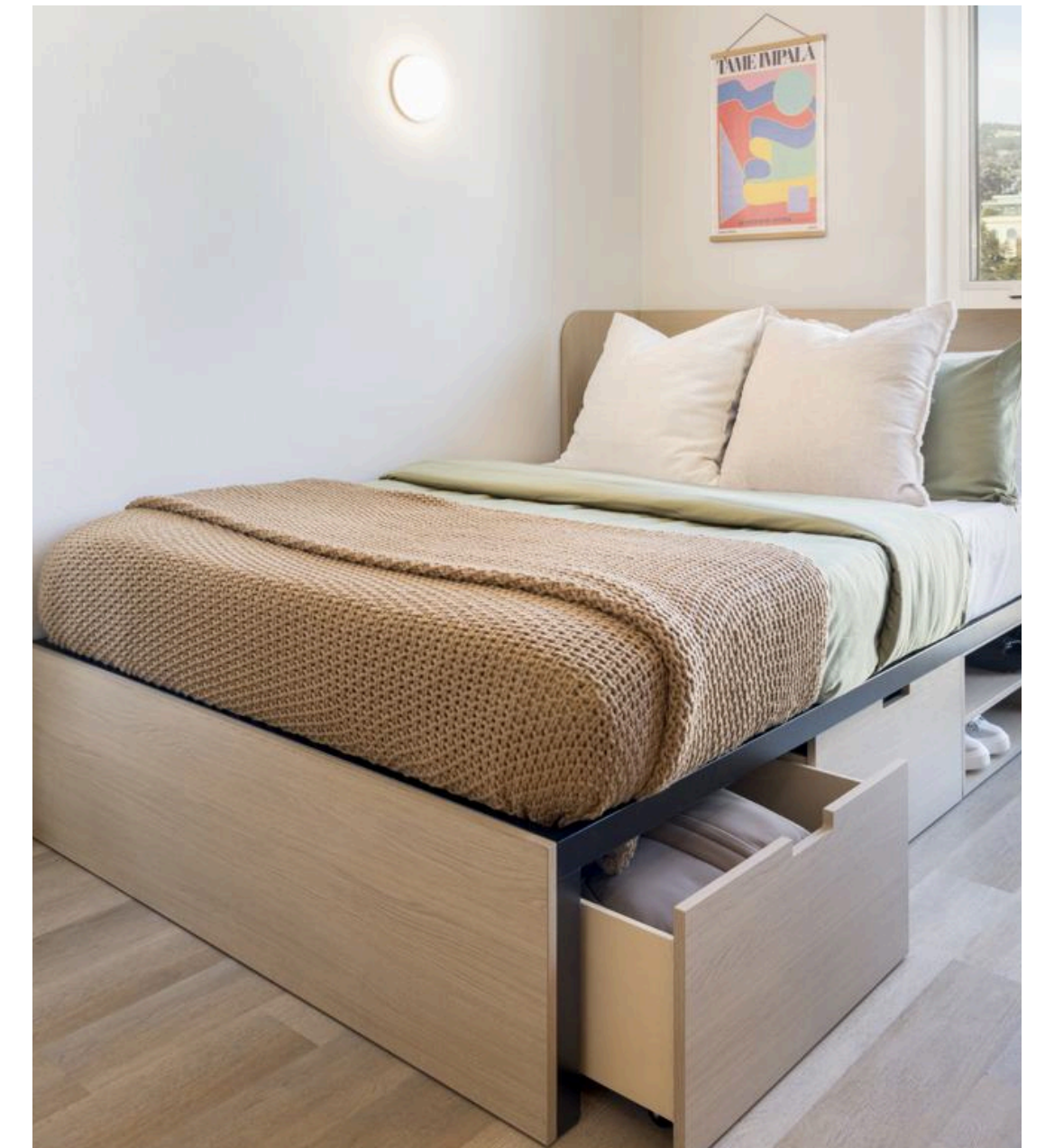

Design driven furniture



Design driven furniture

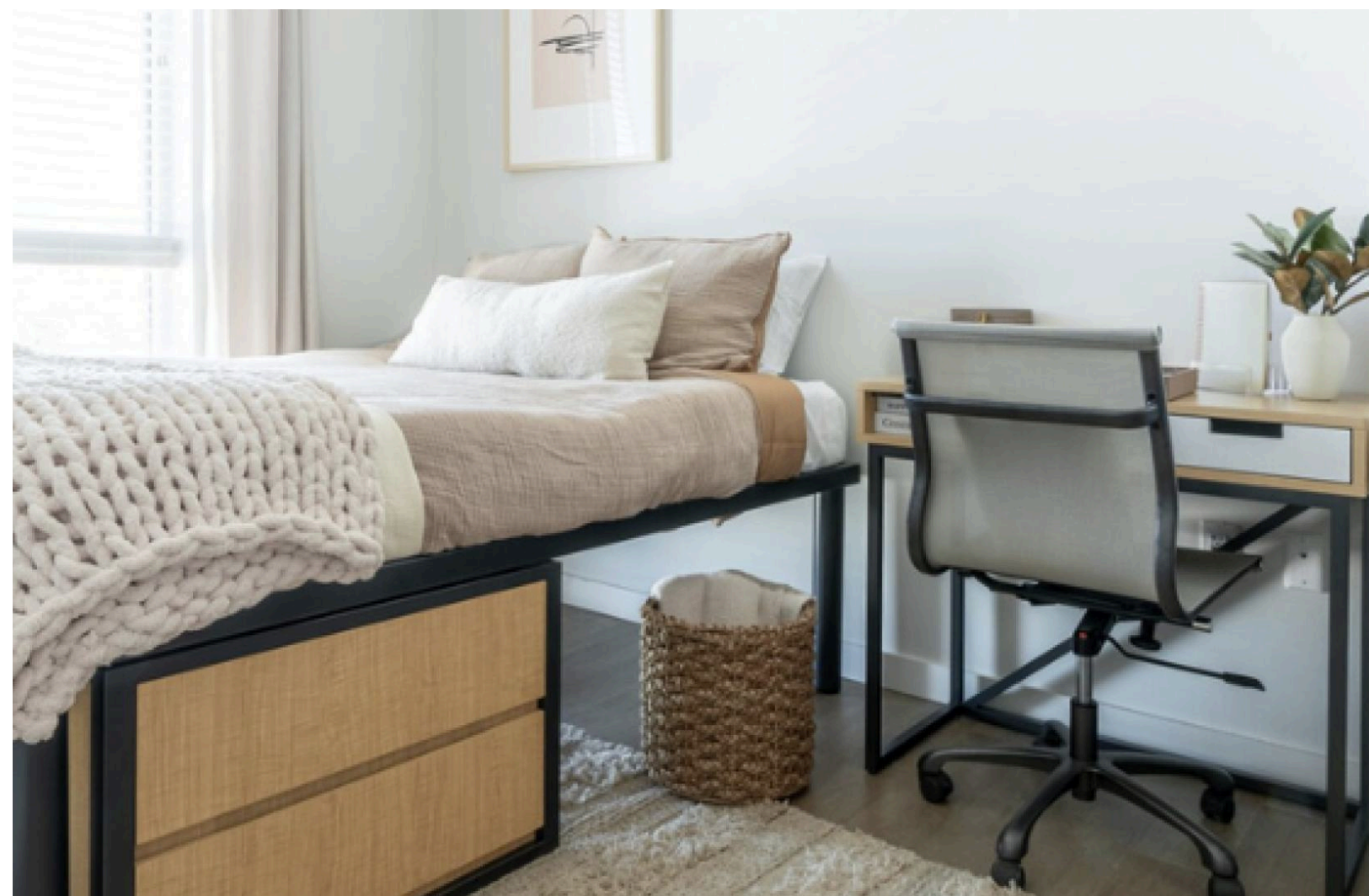

Design driven furniture

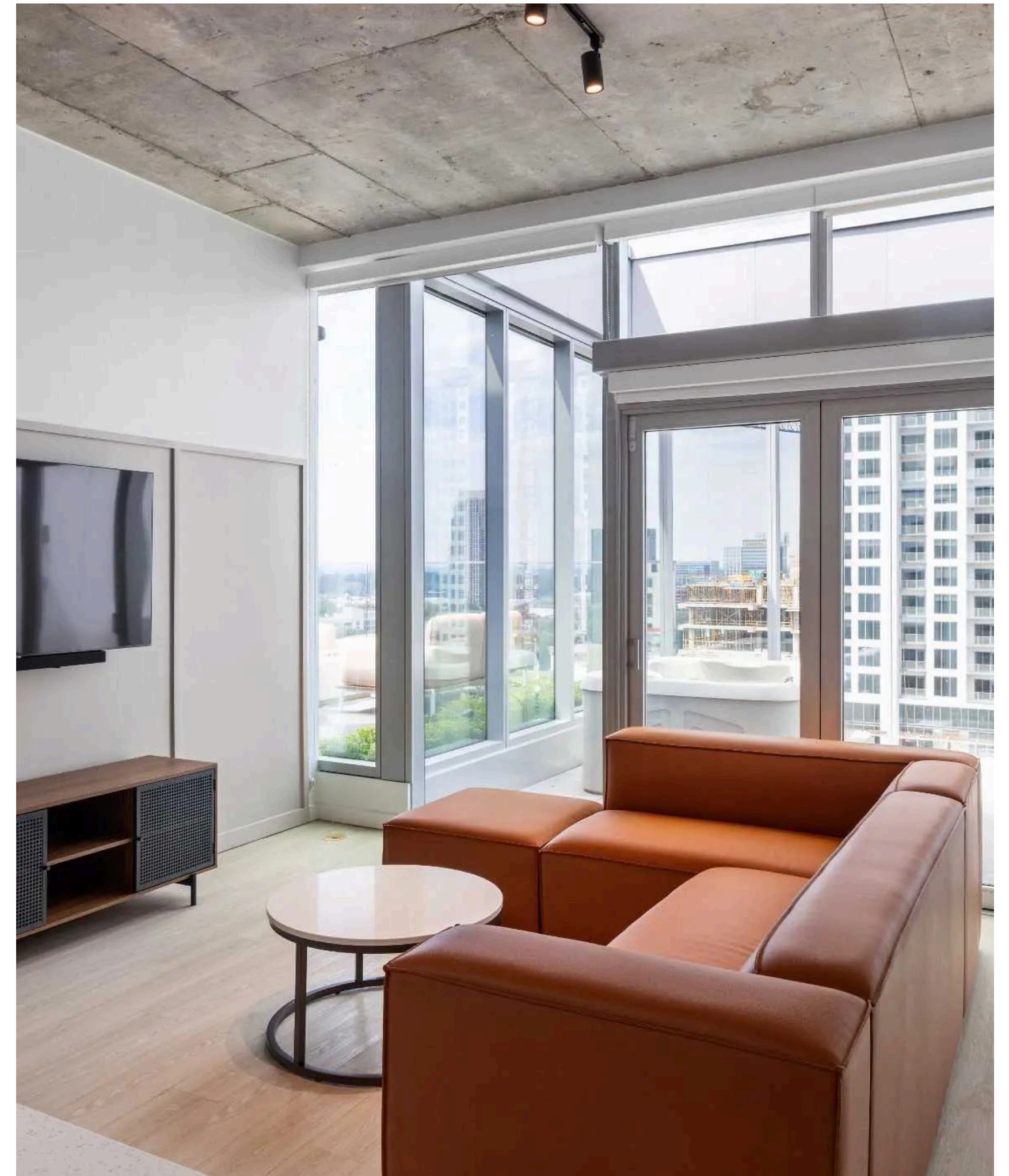

Design driven furniture



Design driven furniture



A few words from our clients

“The most important insurance policy you never knew you needed!”

Owner/Operator · 150 bed development

“I went from 5% to 1% replacements overnight.”

Developer · 100 unit install

“Simply the best in the business!”

REIT · 500 room install

“I just wanted to mention how much we appreciate you guys! I know this back and forth is not easy and you take it with grace and efficiency...”

Large real estate management firm

